

# CT368

## 特点 PRODUCT FEATURES

- 触点负载大
- 强大的防震和减振、可靠性高、寿命长
- PC板安装

## 典型应用 TYPICAL APPLICATIONS

- 汽车、机械设备
- 家用电器、智能家居
- 适合电子设备等合理的控制应用元件

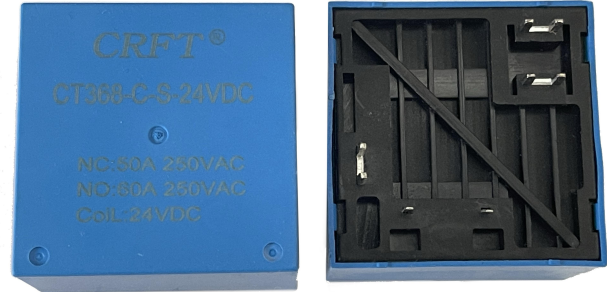

## 触点负载 CONTACT DATA

型号 Model	CT368
额定负载(阻性) Rated load	NO:50A/250VAC; NC:40A/250VAC
最大切换电流 Max.Switching Current	50A
最大切换电压 Max.Switching Voltage	250VAC
最大切换功率 Max.Switching Power	12500VA

## 性能参数 GENERAL DATA

触点材料 Contact material	Silver Alloy		
接触电阻 Contact resistance	100mΩ Max.		
吸合时间 Operate Time	15msec. Max.		
释放时间 Release time	10msec. Max.		
绝缘电阻 Insulation resistance	100MΩ Min.(DC500V)		
介质耐压 Dielectric strength	触点与触点间 Between open contacts		2500VAC 50/60Hz 1min
	触点与线圈间 Between coil & contacts		2500VAC 50/60Hz 1min(可供AC4000V高压)
抗振动 Humidity	稳定性 Functional		10~55Hz, 双振幅 1.5 mm
	强度 Destructive		10~55Hz, 双振幅 1.5 mm
抗冲击 Shock Resistance	稳定性 Functional		10G Min.
	强度 Destructive		100G Min.
寿命 Life	机械寿命 Mechanical Life		10,000,000 次 (10,800次/小时)
	电气寿命 Electrical Life		100,000 次(600次/小时)
环境温度 Temperature Range	-40°C~+85°C		
重量 Weight	约70g		

## 线圈参数 (at 20°C) COIL DATE

额定电压 Nominal Voltage (VDC)	线圈阻值 Coil Resistance at 20°C± 10%(Ω)	最大吸合电压 Max. Operate Voltage (VDC)	最小释放电压 Min. Release Voltage (VDC)	最大过载电压 Max. Applicable Voltage (VDC)
	1.6W			
6	22.5	4.5	0.6	7.8
9	50.6	6.75	0.9	11.7
12	90	9.0	1.2	15.6
24	360	18.0	2.4	31.2

## 订货标记 ORDERING INFORMATION

产品型号 Type	CT368	CT368	-C	-12VDC
触点转换形式 Contact Form	C:1FormC A:1FormA B:1FormB C:1FormC A:1FormA B:1FormB			
线圈电压 Coil Voltage	6V、9V、12V、24V 6V、9V、12V、24V			

## 外形图、接线图、安装孔位图 OUTLINE DIMENSIONS, WIRING DIAGRAM AND PC BOARD LAYOUT

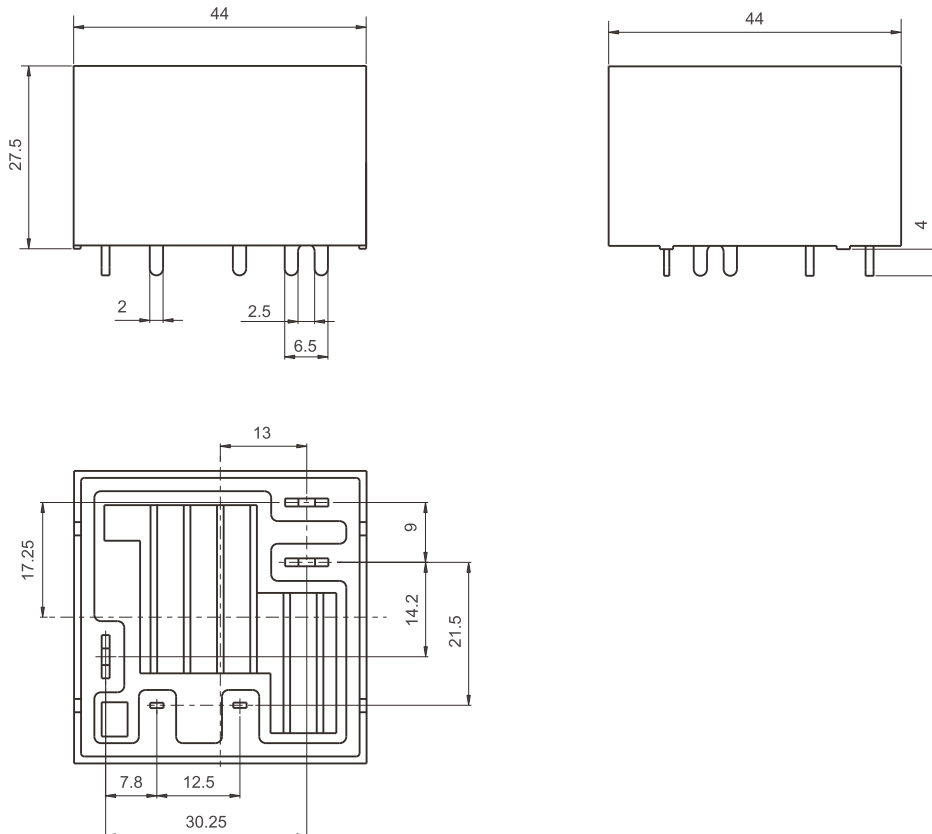

Dimension(mm)  
公差 Tolerance:±0.2

外形图、接线图、安装孔位图

OUTLINE DIMENSIONS, WIRING DIAGRAM AND PC BOARD LAYOUT

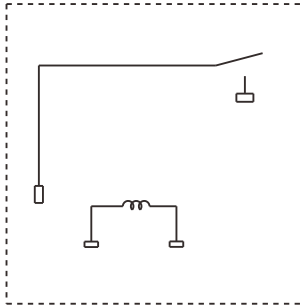

A

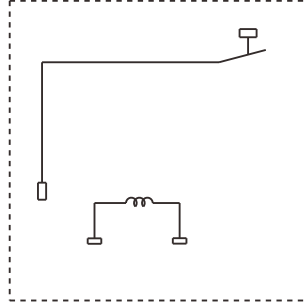

B

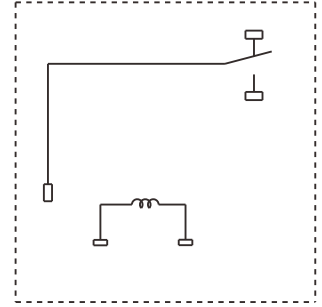

C

接线图

性能曲线图

CHARACTERISTIC CURVES

